

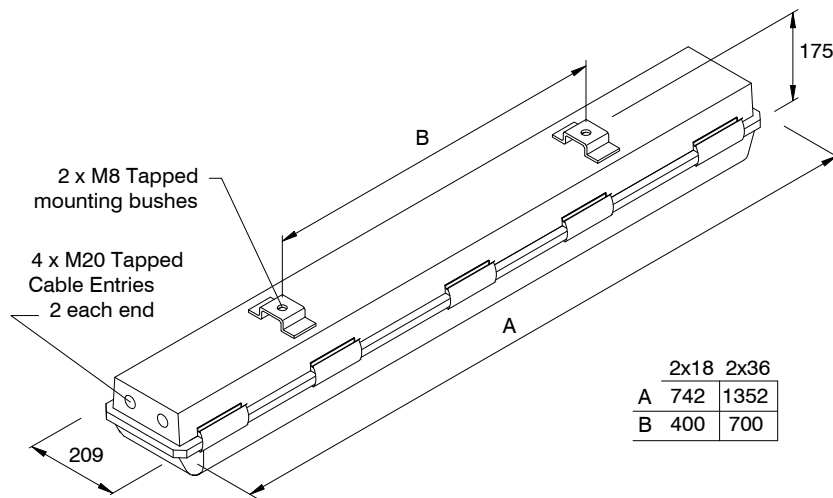

# INSTALLATION, OPERATION AND MAINTENANCE INSTRUCTIONS

## Protecta III Stainless Steel (Bi pin) Emergency

*ATEX & IECEX*

**Important:** Please read the following instructions carefully prior to installation or maintenance of this equipment.



Type Of Protection	Bi Pin with Ex d switch	Ex e mb q (Increased safety, Encapsulation, Powder filling), Ex tb (dust). Ex d e mb q
Protection Standards	(IEC) EN 60079-0, (IEC) EN 60079-1, (IEC) EN 60079-5, ((IEC) EN 60079-7, (IEC) EN 60079-18, (IEC) EN 61241-1	
Area Classification	Zone 1 and Zone 2 areas to (IEC) EN 60079-10-1 Zone 21 and Zone 22 areas to (IEC) EN 60079-10-2	
Installation	(IEC) EN 60079-14	
Certificate	IECEX Certificate of Conformity IECEX BAS 09.0017 EU - Type Examination Certificate Baseefa04ATEX0220	
Equipment Coding	Ex e mb q IIC T4 Gb or Ex d e mb q IIC T4 Gb Ex tb IIIC T85°C Db IP6X -20°C ≤ Ta ≤ +45°C	
ATEX Coding	Ⓔ II 2GD	
Ingress Protection	IP66/67 to EN(IEC) 60529	
CE Mark	 <p>The CE marking of this product applies to "The Electrical Equipment (Safety) Regulations 2006", "The Electromagnetic Compatibility Regulations 2004", the "Waste Electrical and Electronic Equipment Regulations 2006" and the "Equipment and Protective Systems intended for use in Explosive Atmospheres Regulations 1996". [This legislation is the equivalent in UK law of EU directives 2014/35/EU, 2014/30/EU, 2012/19/EU and 2014/34/EU respectively].</p> <p>The Equipment is declared to meet the provisions of the ATEX directive (2014/34/EU) by reason of the EU Type Examination and compliance with the Essential Health and Safety Requirements. M Poutney Technical Manager</p>	

**Luminaire is supplied with Battery plug/Socket disconnected, just prior to switching power on connect battery plug and socket.**

### 1.0 Introduction – Protecta Stainless Steel ATEX & IECEx Model with EOL Protection

This installation leaflet covers the range of Protecta Stainless Steel luminaire models with the Ex q control gear which has EOL circuitry, electronic safety sensor and micro-processor controlled emergency functions. These luminaires are mainly used in harsh environments and are constructed using a marine grade stainless steel body and a polycarbonate diffuser. Refer to the current catalogue for information on product references. The range is available for use with T8 bi-pin lamps to IEC81. The integrated unit consists of a mains supplied ballast for supplying the fluorescent lamps in normal situations, a battery pack, an emergency circuit that charges the battery and powers the lamp in an emergency situation, and a micro-controller based supervisory circuit that controls the charging, monitors the emergency functions and displays the results of self test and emergency unit status by means of a red and green LED. The unit can be connected to an external switch that can inhibit the emergency functions when the mains power is on or off and restart the emergency functions with or without mains power being applied. The terminals for this feature must be specified when ordering.

### 2.0 Electrical Supplies

Lamps	2 x 18W	2 x 36W
Voltage range AC	110-130V or 220-254V	
Frequency range Hz	47-63Hz	
Power Watts 220-254V	40W	77W
Current Amps 220-254V	0.19A	0.36A
Power Watts 110-130V	40W	77W
Current Amps 110-130V	0.38A	0.73A

The safety limit for surface temperature (T rating) is +/-10% on the rated voltage. Equipment should not be operated continuously at more than +10/-10% of the rated voltage of the control gear.

**Batteries** 6V 4Ah NiCd (18W or 36W)  
6V 7Ah NiCd (36W)

**Emergency Duration** 90 minutes or 3 hours depending on model specified

**Emergency Output** 1200mm lamp 25% of normal single lamp output  
600mm lamp 30% of normal single lamp output

- Power Factor >0.98**                      Power is constant over voltage range.
- Over voltage**                              400V ac for 1 min and EN 61000-4-5 > 4kV
- Through Wiring**                            The through current rating is 16A. 4mm<sup>2</sup> terminals are standard (6mm<sup>2</sup> wiring can be specified).
- Storage**                                      Luminares are to be stored in cool dry conditions preventing ingress of moisture and condensation. Storage temperature range to be -20°C to +80°C.  
 Battery packs in storage should be cycled charged/discharged/charged every 9 months, as per instructions below.  
**Always disconnect battery plug and socket for storage.**  
 Any specific instructions concerning emergency luminaires must be complied with.  
 (Warning: Battery packs not cycled and stored for a year may not be recoverable)
- Lamps**                                        The lamps used in the range are T8 bi-pin fluorescent with G13. Lamp caps are to IEC 60061, lamp dimensions and safety to IEC 61195 and lamp performance to IEC 60081. Please note that this luminaire is suitable for IEC lamps only. Do not use American specification lamps.
- Fuse and MCB Ratings**                    It is recommended that for selection of MCBs users should consult the MCB manufacturer as this unit contains electronic control gear. MCB ratings can vary depending on the manufacturer and type and the size of the installation. The electronic control gear has nominal values of inrush current of 30A for 500µs on 230V and 45A for 350µs on 110V.
- EOL Circuitry**                                The Protecta III control gear has circuitry to protect against the potential effects from the end of life condition associated with fluorescent lamps in accordance with IEC 61347-2-3 and 60079-7.

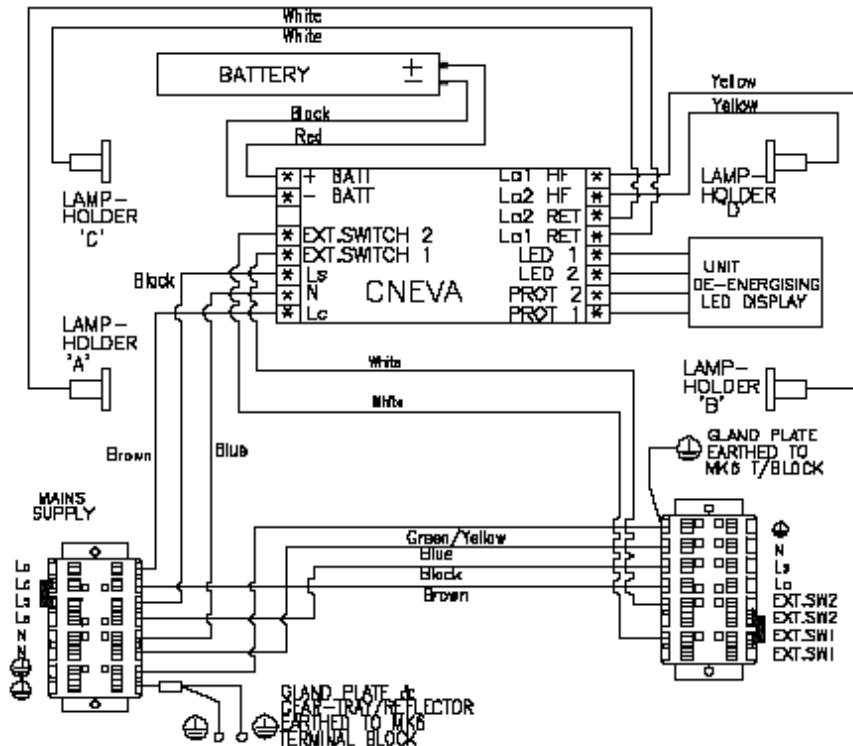

Typical wiring diagram shows circuit with inhibition terminals installed for information only, some models may differ.

### 3.0 Installation and Safety

#### 3.1 General

**These instructions should be read fully and carefully before attempting to install the luminaire. For details of servicing operations, opening etc. see section 6.0.**

Copies of these instructions should be held in a safe place for future reference. It is the responsibility of the installer to ensure that the apparatus selected is fit for its intended purpose and that the installation, operation and maintenance of the apparatus complies with applicable regulations, standards or codes of practice.

Installation should be carried out in accordance with *EN 60079-14* or with a local hazardous area code of practice, whichever is appropriate.

Risk of electrostatic discharge:

- Clean diffuser only with damp cloth
- Avoid mounting near fast moving streams of air

Any specific installation instructions must be referred to. In the UK the requirements of the *Health and Safety at Work Act* must be met and electrical work associated with this product must be in accordance with the "*Manual Handling Operations Regulations*" and "*Electricity at Works Regulations 1989*". Disposal instructions should be complied with.

The luminaires should be considered Class 1 to EN 60598 and effectively earthed.

Certification details on the rating plate must be verified against the application requirements before installation.

The information in this leaflet is correct at the time of publication. The company reserves the right to make specification changes as required without notice.

#### 3.1.1 Use in Combustible Dust Atmospheres

- De-rating of the surface temperature will be required where dust clouds may be present
  - Do not allow dust to accumulate in layers
  - Dust in layers has the potential to form ignitable clouds and to burn at lower temperatures.
  - Refer to EN (IEC) 60079-10-2 & EN (IEC) 60079-14 for additional details of selection and installation

#### 3.2 Tools

3mm and 4mm flat blade screwdriver and large crosshead screwdriver. Suitable spanners for installing cable glands. Pliers, knife, wire strippers/cutters.

#### 3.4 Lamps

The lamps will run until they are worn out. New lamps should be fitted in pairs even if one appears to be still working. If the result is not satisfactory, check continuity to the ballast. If still no result, check the continuity to the lampholders after disconnecting leads from ballast. If no fault found replace ballast. If still no result, disconnect the connection to the sensor. If the lamps light this would indicate a faulty sensor, see 6.9, but as this is most unlikely, check all connections before replacing.

#### 3.5 Mounting

Luminaires should be installed where access for maintenance is practical and in accordance with lighting design information. For horizontal mounting on handrails Chalmit recommend mounting the luminaire with the clamps uppermost therefore allowing the diffuser and gear tray to swing down when necessary. Refer to the note in 3.1 concerning electrostatic charge.

The standard suspension is via two M8 stainless steel bushes. Various adaptors, pole clamps and suspension brackets are available to order.

#### 3.6 Cabling and Cable Glands

The temperature conditions at the supply cable entry point are such that 70°C (ordinary PVC) cable can be used. Equipment certified cable glands and sealing plugs must have suitable IECEx/ATEX approval. When installed the cable gland or sealing plug should maintain the IP rating of the enclosure, however as a minimum a rating of IP64 must be maintained. When a cable gland or sealing plug is installed which reduces the marked IP rating of the enclosure the end user must ensure this is suitably documented. Four entries are provided. Three entries are fitted with suitably approved blanking plugs, the fourth entry with a transit plug. M20 x 1.5 entries are standard, other sizes are available on request. The standard entry configuration is with an earthed metal plate with tapped holes mounted in the body.

#### 3.7 Electrical Connections and Testing

If work other than re-lamping is to be done on any luminaire already connected to the electrical system, the luminaire must be isolated from the system. An external earth is fitted.

To access the mains terminals; firstly swing the diffuser down, the four gear tray fixing screws are loosened then slide the reflector/gear tray over the slots and swing the reflector/gear tray down. Luminaires are supplied suitable for looping and

through wiring. Screw type or screw-less “cage clamp” terminals are fitted in the range of luminaires. Mains terminal blocks on the emergency luminaires are marked Lc Ls N Earth.

Luminaires can also be supplied with three phase wiring to special order. The marking is L1 L2 L3 (L s) N Earth.

Switching the voltage on the Ls connection enables the luminaire to be switched on and off without the emergency function being activated. The Ls connection is insulated from L and has a signal function only drawing a very small current.

The emergency units can be connected as switched, un-switched or non-maintained units. The switching facility is to allow the luminaire to be switched off whilst still charging the battery. Where switching is required, the un-switched line (Lc) is connected to the continuous mains supply. A link is fitted during assembly between Lc and switched line (Ls); this is removed for the switch-able mode. If the link is removed and Ls not supplied, the unit will only operate on emergency.

If the emergency luminaire is on a three phase system the switched line can be on any phase, it does not need to be on the phase connected to the un-switched line.

The maximum amount of insulation allowed beyond the throat of the terminal is 1mm. The normal method of insulation testing is to connect Live and Neutral together and test between this point and Earth to prevent the risk of damage to the electronic control gear. However, if this is not possible luminaires can be tested with an insulation tester that complies with IEC 364 or BS 7671 with a maximum output current of 1mA and output voltage of 500V dc. (Units damaged by incorrect insulation testing can be detected).

Before completing the wiring, ensure that all the connections are correctly introduced into place before reassembling the luminaire. New lamps should be fitted.

#### 4.0 Emergency Operation

##### 4.1 General description of operation

The luminaire will go seamlessly into emergency mode at not less than 60% rated supply voltage and will remain in mains mode above 85% of rated supply voltage.

On restoration of the mains supply there will be a **60 sec delay** before the emergency lamp is restored to mains operation.

This feature is not common on emergency luminaires and should be noted. The feature is provided to increase reliability when operating in bad supply conditions.

The charging function is monitored continuously; there is a check for over charging and no charging. In case of a control gear fault three red flashes, followed by a pause are displayed.

After a complete battery discharge, the unit will switch over to a low discharge current mode.

##### 4.2 Automatic Self Testing

A manual test of emergency duration can only be made by manually de-energising the luminaire and timing the discharge.

The LED must be constant green to show that charging has been completed before commencing this test. The LED indication will show if the emergency battery duration is too low.

The electronic ballast continuously monitors all charging functions.

The unit will carry out a short self test every 13 days. This short self-test is to check battery emergency operation. The test will commence at a random point in the 13 day cycle, starting at the first mains energisation after the battery is connected or re-connected. During the 13 day self test the unit will test for function including lamp condition. The test will last 9 minutes with one lamp being energised at emergency level during the test period, the other lamp will remain on. If Ls is off, the short test is delayed until Ls is re-energised.

The unit will perform a complete battery discharge every 102 days and will check for minimum emergency duration as stated above. The start of the first complete battery discharge is at a random point between 0 and 102 days after applying mains voltage. The test will be repeated at fixed 102 day intervals. The unit will also complete a full self test after completing a commissioning cycle to full charge and after battery replacement. The full commissioning cycle takes about 50 hours after which the battery will then be re-charged.

The test will be delayed if the battery is not fully charged or the operating temperature at the time is too high to give a proper result. The test is also carried out after the initial installation and energisation and a full charge cycle completed. During the test one lamp remains energised at normal mains output. The long test will also take place once the charge period is complete after a battery is changed or disconnected then re-connected.

The emergency lamp condition is monitored during every lamp start. If the lamp ignition is not correct the LED will display repeated red flashes. This will happen even if the lamp does ignite and run at the normal light level as the system predicts imminent failure before it occurs.

If the self-test detects a failure it is indicated as per the table below by the LED. At the start of the automatic long test the emergency lamp will switch off for 9 mins so that it can cool down and make the starting test valid.

Refer to the Table 1 below.

Emergency lamp defective: continuous red flashing.

Battery defective or low capacity: two red flashes, followed by a pause.

Emergency unit defective: three red flashes followed by a pause.

If the charge condition is known, the unit will re-charge from empty to approximately 80% charge in 14 hours. Afterwards a reduced current post charge will be applied to complete the charge. If the battery charge condition is unknown (e.g. first connection) a reduced charge is applied for 44 hours.

For battery temperatures below 10°C charge current is reduced and charge time increased.

The charging function is monitored continuously, there is a check for over charging and no charging. In case of a fault three red flashes, followed by a pause are displayed.

After a complete battery discharge, the unit will switch over to a low battery discharge mode which maintains the memory and monitoring function. The control contains dedicated features which prevent any unsafe condition arising if the micro-processor were to malfunction.

**LED display**

The status is displayed by means of red and green LED signals.

The green LED will flash slowly, if the batteries are being charged, and all emergency functions were found to be OK during the last self-test.

The green will be steady at full charge.

The red will flash if there is a fault or a warning.

Table 1 Monitoring function indication

GREEN	RED	MODE	REMARKS
Continuous fast flash 1 per Second		Charge C/10	Charging currents at low temperatures reduced
Continuous slow flash 1 per 2 Seconds		Charge C/20	
Steady		Fully charged	
Fast Flashing alternate Red-Green	Fast flashing alternate Red-Green	(a) 15 min remaining on standard (90min) version (b) 30min remaining on 3hour / (3h) version. Also see 5.2.2	One lamp at emergency light level
	fast flashing	Emergency lamp near end of life	Both lamps on or off
	2 red flashes repeating	Battery faulty or battery not connected or low duration after long test	Minimum duration limit during long test not met
	3 red flashes repeating	Fault in electronics of power supply	
Slow flash or steady	Periodic short flash once per 4 secs	Emergency inhibited	
None	None	Defective display	Lamps on
None	None	Mains off, battery discharged, or mains off inhibited or total unit defective	Lamps off

**4.3 Inhibition (also see 3.7)**

If local emergency inhibition is required the luminaire should be ordered with the connections for this feature built in. The electrical wiring will consist of two connections to the control gear brought out to an extra terminal block at the mains supply terminals. Closed circuit is normal, open inhibits the emergency function. Up to ten luminaires can be connected in parallel to one switch and using 500m of cable.

The inhibit as well as de-inhibit functions can start with normal mains power present as well as without mains power, the emergency light can be switched on while the whole system power is still dead.

Inhibition is not possible with a completely discharged battery and no mains being present. The emergency function can be inhibited and de-inhibited whilst in emergency operation. Return to emergency operation is instant. The change to lamp off when put into inhibited mode may be delayed for up to 60 secs, If the inhibition is connected into a circuit with CEAG emergency luminaires having an inhibition connection the Protecta must be connected as follows EXT SW1 should be connected to CEAG "2" EXT SW2 should be connected to CEAG "3".

As there are four entries, four core cable must be used for looping the inhibition terminals if the mains through wire connection is to also be used. If any other configuration is needed it must be specially ordered or the internal wiring pack changed on site.

**5.0 Commissioning (Refer to section 6.0 for access)**

The units will only be fully operational and give completely correct indication after the completion of a full charge, self-test discharge and recharge cycle, approx. 80-100 hours. Once this is complete the unit will have it's full operating parameters installed in the memory. Provided the battery is not disconnected indication will function correctly. Non-emergency luminaires are energised after the lamps are fitted and the luminaire closed if the mains is on. Both lamps should light. Opening the cover will put the lamps out.

### 5.1 Commissioning with no mains power available.

After inserting the lamps and closing the cover, the unit will go onto emergency mode until discharged if the initial battery voltage is high enough. (> 5.5V).

If the emergency inhibition switch is in the blocked condition the lamp will go on for 60 seconds unless there is not enough charge in the battery to sustain it for that time.

### 5.2.2 Commissioning with mains power available.

Luminaire is supplied with Battery plug/Socket disconnected, just prior to switching power on connect battery plug and socket.

If a local light switch is connected put it on.

After inserting the lamps and closing the cover the unit will light on battery as above. At power up the mains lamp will light and emergency lamp will light fully after 60 secs. This feature is designed to increase reliability in very frequent mains on and off situations or irregular supply such as may occur during commissioning.

The initial charge will be indicated by a green flashing LED.

If an emergency blocking switch is present a short red flash every 4 sec will be displayed if the switch is in the blocked state.

If the battery charge condition is unknown (e.g. first connection) a reduced current charge is applied for 44 hours.

The long self test takes place after the initial installation and energisation has been made and a full charge cycle completed.

The test will be delayed if the operating temperature at the time is too high to give a proper result or if Ls is off. One lamp remains energised at normal mains output. **See 4.2.** After the test the unit will fast charge to 80% then post charge to fully charged and the indication will then be steady green.

Until the full charge and test cycle has been completed the unit will indicate low battery on any emergency discharge.

### 5.2.3 Low Temperature Operation

At battery temperatures below 10°C charge current is reduced and charge time increased. This temperature is equivalent to the luminaire operating at -5°C with the lamps on or at +5°C with the lamps off.

Under operating conditions where the ambient temperature is below 0°C for long periods the luminaire should preferably be used in maintained mode so that the mains supplied lamps warm up the battery to a normal working temperature.

## 6.0 Servicing and Operation

The bi-pin luminaire incorporates an electronic safety de-energiser for maximum reliability and utility of the emergency monitoring function. The electronic sensor is operated by the actuating plate on the diffuser. This provides for the safe opening and carrying out of re-lamping.

**Safe servicing behind the gear tray requires the mains supply to be isolated, and battery connections must be treated with care, see 6.10.**

### 6.1 Opening and Closing the Cover

The procedure for opening the diffuser on the Stainless Steel models is as follows:

Insert the tool under the stainless steel clamp with the end of the tool located, a wide blade screwdriver is recommended. Gently lever the tool upwards towards the diffuser and the clamp will begin to open. Repeat the procedure for all the clamps. The integral hinge will retain the cover.

The procedure for closing and securing the cover is as follows:

Ensure the hinge mechanism is clear of any obstruction and then swing the diffuser into the closed position.

Support the diffuser in position whilst pushing each of the clamps over the edge of the diffuser.

### 6.3 Fitting lamps and Re-Lamping

**IMPORTANT** - If the luminaire is maintained with the power on, the lamps will go out when the cover is opened. If this does not happen there is a fault. Do not remove the lamps. The control gear will be damaged if the lamps are removed without being de-energised and there is an ignition risk. This could occur if the sensor arrangement is faulty or has been defeated. The luminaire must be de-energised the control gear checked and electronic sensor assembly must be replaced if faulty, see 6.9.

**Lamps which are not operating or appear dim should be replaced as soon as practical.** The control gear is designed to withstand end of life conditions of lamps. The emergency unit will indicate in advance that the lamp is approaching end of life. Always replace both lamps.

The bi-pin lamps are fitted in lampholders with a rotating section. The lamp must be pushed firmly down into the lampholder and rotated 90°. The contact is biased to remain in the 90° position. If the lamp does not rotate, check that it is completely positioned into the lampholder. Before inserting bi-pin lamps ensure the lamp pins are not damaged or slack in the end cap.

### 6.4 Releasing the Reflector/Gear Tray

Loosen the four fixing screws retaining the reflector/gear tray far enough for it to slide over keyhole slots. The tray will hang on the retaining cords without stressing the wiring between body and tray. Replace in reverse order.

The lampholder assemblies can be removed from the gear tray, if necessary, by removing the fixing screw and pushing up the click finger at the end of the gear tray and pushing the lampholder assembly forward towards the centre of the tray.

Re-assembly is a reversal of the above, ensure the lampholder assembly fully clicks into place on the gear tray. Lampholder assemblies have the connecting receptacles and are specific to each model. If they are being replaced the correct spare assembly must be ordered.

### 6.5 Removal of Reflector/Gear Tray c/w Lampholder Assemblies

Release gear tray from body and hang on retaining cords, as explained above. Disconnect the cables from the gear tray to the mains terminal block, unhook retaining cord from gear tray and lift clear. With disconnection made at the screw-less terminals the luminaire is safe when re-closed without the tray.

### 6.6 Servicing Behind the Gear Tray

**The release of the gear tray exposes live mains terminals. Any work behind the gear tray requires that the supply is isolated to avoid ignition risk and damage to components.**

### 6.7 Replacement of Ballast or Emergency Control

The ballast contains no replaceable parts. Should it be found necessary to replace the ballast, the following procedure should be adopted:

Ensure that the luminaire is isolated from the mains supply.

Remove gear tray from body and swing down as previously explained. Undo the battery plug on emergency luminaires.

Ballasts use locking tab connectors which are released when the black cover sleeve is pulled away axially. When replaced a 'click' will be heard as the lock locates. **On no account should the quick release connectors be replaced with proprietary items.**

Disconnect the leads to the ballast, note the connections. When removing the connections **always disconnect** the sensor and LED connections (LED1 LED2 PRPT1 and PROT2) **last** and reconnect them **first**. Remove the ballast retaining screws and remove ballast from tray.

Replacement of the units is in the reverse order. **The sensor is connected first and the battery last.** Check the connections carefully before re-energising. The lamp leads on the emergency are marked as pairs. Take care to connect correctly. The unit is **not** protected against reverse battery polarity. The yellow leads are the high voltage ones. Misconnection of the units will be very likely to result in damage. **Care and checking during replacement can not be over emphasised.**

### 6.8 Replacement of Micro Switch if fitted

Before carrying out any work ensure that the unit is isolated from the mains. Identify the four micro switch wires and disconnect from the terminal block. Free the leads from the retaining connections, remove the two screws holding the switch in position. Replace the micro switch and reconnect. Check the connections and terminal polarity against either a circuit diagram or a note made prior to dismantling. A complete new assembly including the connecting receptacles for the model must be used.

### 6.9 Replacement of sensor with or without LED assembly

It is very unlikely that this assembly will need replacement other than as a result of mechanical damage.

Isolate the mains. Disconnect the battery, disconnect the sensor and note the connections. Undo the two screws and replace the unit using the nuts from the old unit. Reconnect and carefully check the connections before re-energising.

### 6.10 Replacement of battery

The battery is connected to the control using a plug and socket arrangement. The battery load is disconnected by the electronic sensor device. The screws holding the battery pack are loosened and the battery pack slid axially one way then the other in order to release. Upon replacement of the battery pack remember to tighten the screws. The battery pack is not intended to be opened and is replaced as a unit. The battery is potentially incandive but is protected during removal by the IP30 construction which covers live parts. **The battery assembly must be protected from damage and water ingress then removed from any potentially hazardous area as soon as practical.**

The luminaire must not be operated without the battery connected. If the battery is removed and not replaced the control gear supply must be disconnected at the mains terminal block and secured.

### 6.11 Checking of Battery separately

If the battery is to be checked separately, it should be charged using a **constant current charger** at 200/400mA for 30/15 hours for the 4Ah (18W or 36W) or 350/700mA for 30/15 hours for the 7Ah (36W). Discharge measurement is not easy as the current is proportional to the voltage for resistance loads, so it has to be averaged. Discharge the battery at 1 to 2A and multiply current by time. Do not discharge below 1 volt per cell, which is 5V. The capacity should be 75% or more of normal.

## 7.0 Routine Maintenance



Visual tests and checks should be carried out at intervals described by the appropriate regulations, EN 60079-17, and should include the following:

Check that the lamps are working or appear badly aged. Blackening at the lamp ends is a good indication of ageing.

- Check for mechanical damage/corrosion.
- Check connections, fixings, glands and plugs.
- Check for undue accumulations of dust, dirt or moisture.
- Check for unauthorised modifications.

Periodic inspection of the enclosure seal should be carried out to ensure that the seal is sound. The seal can be replaced and, if necessary, secured in position by the application of a **very** small amount of rubber adhesive and using the joining piece. If the luminaire has been subject to abnormal conditions, for example, severe mechanical impact or chemical spillage, it must be de-energised until it has been inspected by an authorised and competent person.

### 7.1 Cleaning

The body of the luminaire may be cleaned with a mild solution of household detergent and water, after cleaning the body should be washed and wiped with clean water. **The diffuser should not be polished or wiped with a dry cloth as a risk of ignition due to electrostatic discharge may result.** Cleaning of the diffuser with any chemical or hydrocarbon solvent based cleaner may result in severe damage.

### 7.2 Fault finding

For emergency units this concerns faults other than ones that are properly indicated, refer to the indication table.

Check for operation of the LED. **If the LED is red** refer to the table which shows the fault diagnostics. If the unit does not work on the mains with Ls energised carry out the checks in 7.1.1. If mains operation can not be restored replace the control unit.

A service operation, that is opening and closing the cover, will often re-set faulty lamp indication but the indication will reoccur so the lamp must be changed.

If fault finding is done on an emergency unit before a full commissioning cycle has been completed care must be taken to ensure that the faults are real. Check that the inhibition circuit is complete, see 3.7 and 4.3.

With faults occurring later the first action is always to fit new lamps. If the unit does not work on mains with both lamps, 60 sec delay on emergency lamp, and Ls is powered there is a fault. The second action is to fit a new battery *with some charge in it*. These actions can be done with the luminaire installed. If the result appears positive leave the luminaire in place for a charging period. If changing batteries always use one with some charge. A voltage of 6.0V will be enough to avoid problems. See 6.11.

Except for checking continuity to the supply and ballast input connections there is little that can be done to fault find using instruments. Care is needed in the workshop as mis-connection will damage units. Always check connections carefully. Live testing and use of meters on high frequency units in a workshop will gain little information and may damage healthy components.

The usual first service operation with emergency units which appear to work normally on mains but not on emergency is to energise for a few minutes before checking emergency operation. If no result, check that the inhibit connection is closed circuit. If the unit works on emergency let it discharge fully. The unit should then be energised for 60 mins and the discharge re-checked.

If the unit runs for a few minutes it is charging. If not, change the battery and repeat the full discharge and short charge test.

If okay, give the unit a full 48 hour charge and check the duration. If there are still fault indications replace the control unit.

## 8.0 Disposal of Material

### General

Disposal of the luminaire as waste should be carried out in accordance with national regulations. Any disposal must satisfy the requirements of the [WEEE directive \[2012/19/EU\]](#) and therefore must not be treated as commercial waste. The unit is mainly made from incombustible materials. The control gear contains plastic, resin and electronic components. All electrical components may give off noxious fumes if incinerated.

### 8.1 Lamps

Fluorescent lamps in modest quantities are not "special waste". They should be broken up in a container to avoid injury, avoid inhaling dust.

**Important:** *Do not incinerate lamps.*

**8.2 Battery Disposal**



Nickel cadmium batteries are defined as 'controlled waste' under the hazardous waste regulations and the person disposing needs to observe a 'duty of care'.

Batteries can be returned to the manufacturers for recycling. They must be stored and transported safely and any necessary pollution control forms completed prior to transportation. Take care to fully discharge batteries before transporting, or otherwise ensure that there can be no release of stored energy in transit. For further details refer to our Technical Department.



To comply with the Waste Electrical and Electronic Equipment directive 2012/19/EU the apparatus cannot be classified as commercial waste and as such must be disposed of or recycled in such a manner as to reduce the environmental impact.

**Chalmit Lighting is a leading supplier of Hazardous Area lighting products**

	<p><b>CHALMIT LIGHTING</b> PO Box 5575 Glasgow, G52 9AP Scotland</p>	
<p>Telephone: +44 (0) 141 882 5555 Fax: +44 (0) 141 883 3704 Email: <a href="mailto:info@chalmit.com">info@chalmit.com</a> Web: <a href="http://www.chalmit.com">www.chalmit.com</a></p>	<p>Registered No: 669157 Registered Office: Cannon Place 78 Cannon Street London EC4N 6AF UK</p>	

**For technical support, please contact: [techsupport@chalmit.com](mailto:techsupport@chalmit.com)**

Note: Chalmit Lighting reserves the right to amend characteristics of our products and all data is for guidance only.

	<b>EU-Declaration of conformity</b>		
	<b>UE-Déclaration de conformité</b>		
	<b>EU-Konformitätserklärung</b>		
Manufacturer	Chalmit	Address	388 Hillington Road, Glasgow. G52 4BL Scotland UK
Product	Protecta III Stainless Steel Fluorescent Emergency Luminaire (Bi Pin)		
EU - Type Examination Certificate	Baseefa04ATEX0220		
Notified Body	SGS FIMKO OY 0598		
ATEX Coding	 II 2 GD	ATEX Classification	Group II Category 2 GD
Equipment Coding	Ex e mb q IIC T4 Gb, Ex tb IIIC T85°C Db or Ex d e mb q IIC T4 Gb, Ex tb IIIC T85°C Db IP6X -20°C ≤ Ta ≤ +45°C		
Ingress Protection	IP66/67		
The technical basis, with respect to equivalence of			
La base technique, en ce qui concerne l'équivalence de			
Die technische Grundlage hinsichtlich der Normen			
Protection Standards EN 60079-0, EN 60079-1, EN 60079-5, EN 60079-7, EN 60079-18, EN 61241-1			
Area Classification EN 60079-10-1 and EN 60079-10-2			
of compliance with the EHSRs is valid as there are no changes which materially affect the state of technological progress of the product.			
en conformité avec les EESS est valide puisqu'il n'y a aucun changement qui affecte matériellement l'état de l'évolution technologique du produit.			
zur Erfüllung der GSGA ist gegeben, da keine Änderungen erfolgt sind, die einen Einfluss auf den technischen Stand des Produkts haben.			
Terms of the directive:		Standard & Date Certified to	Standards Date Declared to
Prescription de la directive:		Standard & date certifiée à	Normes date Déclaré
Bestimmungen der Richtlinie:		Standard & Datum Zertifiziert nach	Standards Datum erklärt
2014/34/EU	Equipment and protective systems intended for use in potentially explosive atmospheres.	EN 60079-0 : 2009	2012
		EN 60079-1 : 2007	2014
2014/34/UE	Appareils et les systèmes de protection destinés à être utilisés en atmosphères potentiellement explosibles.	EN 60079-5 : 2007	2015
		EN 60079-7 : 2007	2015
2014/34/EU	Geräte und Schutzsysteme zur bestimmungsgemäßen Verwendung in explosionsfähigen Bereichen.	EN 60079-18 : 2004	2015
		EN 61241 : 2004	EN 60079-31 : 2014
2014/30/EU	Electromagnetic compatibility	EN 55015 : 2013	
2014/30/UE	Compatibilité électromagnétique	EN 61547 : 2009	
2014/30/EU	Elektromagnetische Verträglichkeit	EN 61000-3-2 : 2014	
2014/35/EU	Low voltage equipment	EN 60598-1 : 2015	
2014/35/UE	Équipements électriques à bas voltage	EN 60598-2-22 : 2014	
2014/35/EU	Niederspannungsgeräte / -systeme	EN 60529 : 1992	
2012/19/EU	Waste of electrical and electronic equipment	Shell Deluge DTS-01 : 1991	
2012/19/UE	Déchets d'équipements électriques et électroniques	Seismic EN 60068-3-3 : 1993	
2012/19/EU	Entsorgung der elektrischen und elektronischen Geräte / Systeme	Nuclear Seismic IEC 60980-6 : 1993	
2011/65/EU	RoHS II Directive		
Additional information:	The luminaire is capable of withstanding over voltage levels of up to 400V AC for 1 minute and impulse voltage surges of 4kV.		
Informations complémentaires:	Le luminaire peut supporter des niveaux de tensions jusqu'à 400V CA pendant 1 minute et des tensions de choc de 4kV.		
Zusatzinformation:	Dieser Strahler widersteht Überspannungen bis 400V AC 1 Minute lang sowie Stoßspannungen von 4kV.		



On behalf of the Chalmit, I declare that, on the date the equipment accompanied by this declaration is placed on the market, the equipment conforms to all technical and regulatory requirements of the above listed directives.

En tant que représentant du fabricant Chalmit, je déclare qu'à la date où les équipements accompagnant cette déclaration sont mis sur le marché, ceux-ci sont conformes à toutes les dispositions réglementaires et techniques des directives énumérées ci-dessus.

Hiermit bestätige ich, im Namen von Chalmit, dass am Tag der Lieferung des Produkts/der Produkte zusammen mit dieser Erklärung das Gerät/die Geräte alle technischen und regulativen Anforderungen der oben aufgeführten Direktiven erfüllt.

Name and Date	Mark Poutney	01/01/2021	Technical Manager	
Nom et Date			Directeur technique	
Name und Datum			Technischer Leiter	
Quality Assurance Notification by:	<b>SGS FIMKO OY</b>	Quality Management System Accreditation:	<b>ISO 9001</b>	
Notification d'assurance qualité par:	<b>0598</b>	Certification du système de gestion de la qualité:	by/par/durch	
Qualitätssicherungsnotifikation durch:		Qualitätsmanagementsystem Akkreditierung:	<b>Loyd's Register</b>	
		<b>Certificate No./Certificat N°/Zertifikat Nr.</b>	<b>LRQ 4005876</b>	